

**L  
A  
B  
S  
O  
F  
T**

# **LaboTex**

Version 3.0

**The Texture Analysis Software for Windows**

## **LaboTex: Skeleton Lines and Misorientation Diagrams**

**LaboSoft s.c.**

**Phone: +48 12 6443733**

**Fax: +48 12 3953891**

**E-mail: [office@labosoft.com.pl](mailto:office@labosoft.com.pl)**

**@ LaboSoft 1997-2005**

## 1. Section and skeleton lines

Some materials tend to develop orientation densities around to crystallographic axis. LaboTex allows write to database  $\langle hkl \rangle \parallel ND$  orientations as  $\langle hkl \rangle$  fiber. These orientations are very important for analysis samples with axial symmetry. From LaboTex version 3.0 you can also make comparison of ODFs for arbitrarily sectioned ODF. Some orientation ‘tubes’ in Euler space are used to analysis of texture in metals and these orientations are also called as **texture fiber** (fibre). There are defined  $\alpha, \beta, \gamma, \eta, \zeta \dots$  fibers. Position these orientations in Euler space can be different when you analyzing fcc, bcc or other metals. Some authors use also differently defined fibre orientations, hence in LaboTex you can defined these orientations (sections in Euler space) freely. For example:  $\alpha$ -fiber for fcc metals is defined along the section between Goss and Brass orientations /Humphreys,Hatherley/ :

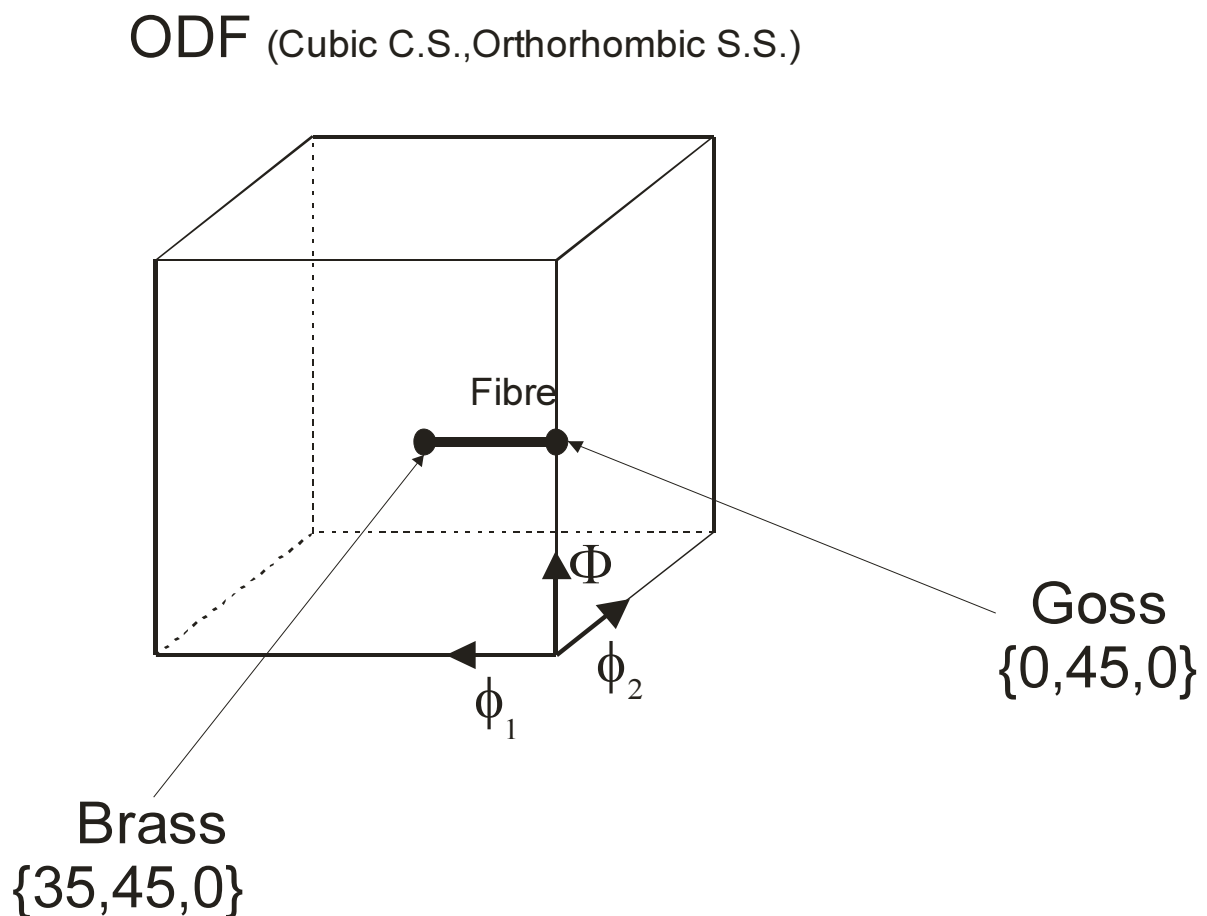

You can defined this section in LaboTex when you are displaying projection of ODF for current sample (you have calculated ODF, button 'ODF' is checked and button for ODF projection:  $\phi_1$ ,  $\phi_2$ , or  $\Phi$  is on):

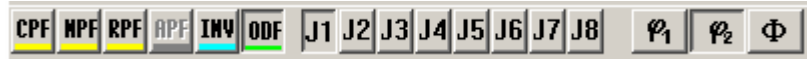

Choose '2D' option (option available from main toolbar):



Next you can see from right side of ODF new dialog window : 'ODF- 2D User Defined Diagrams':

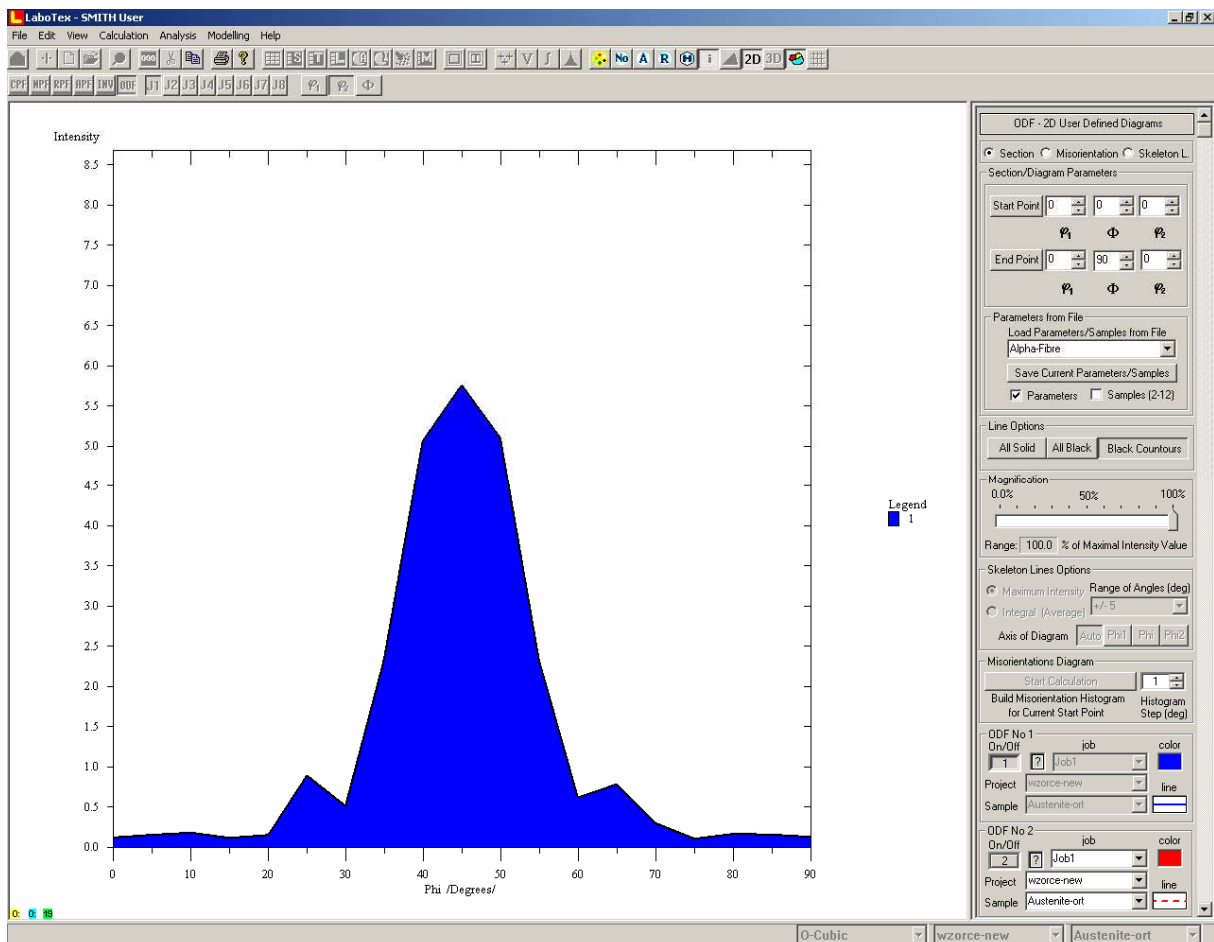

Next user should define two points in Euler Space: start point and end point for section. User can write Euler angles directly or can choose its from database.

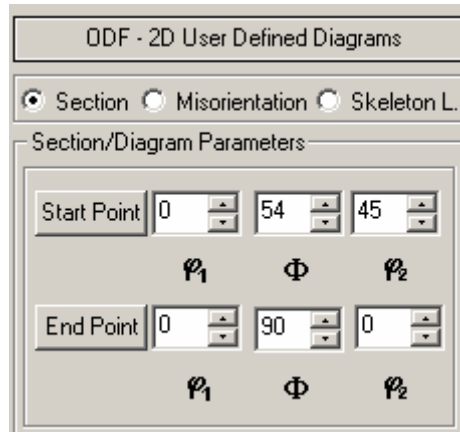

If you would like choose start (end) orientation from database then click on the 'Start Point' (or 'End Point') button:

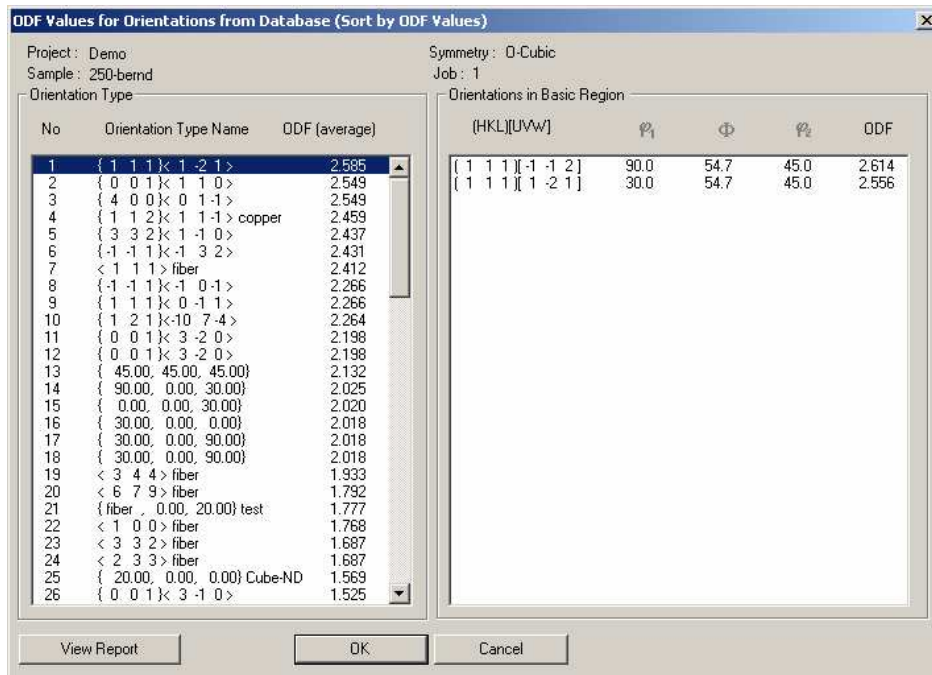

Next choose orientation type from left list and one from symmetrically equivalent orientations from right list. LaboTex shows ODF intensity along section defined on the base these points. Comparison up to 12 ODFs is possible. The first ODF is current ODF (displayed ODF). Other ODFs to comparison you can choose using combo boxes for:

- 1) Samples;
- 2) Projects;
- 3) Jobs.

For activate ODF section press On/Off button:

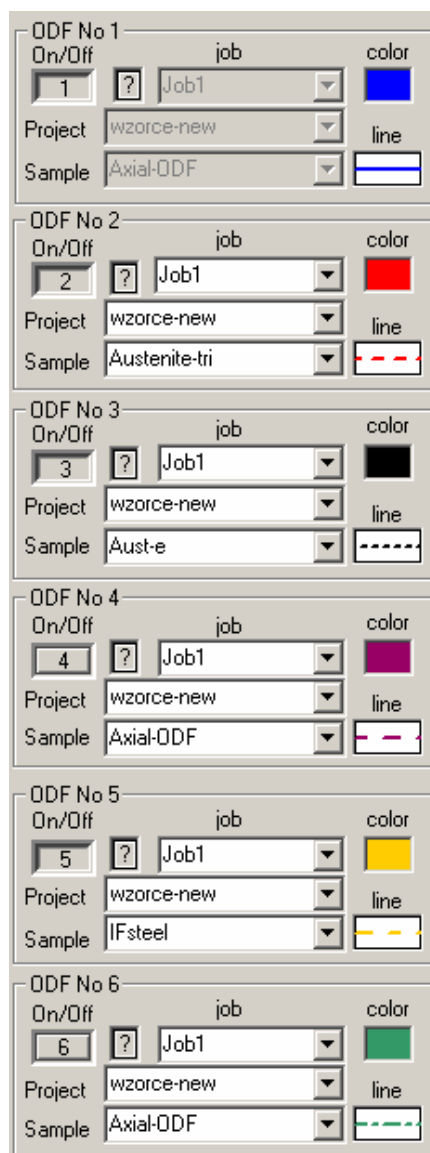

There are many options to **optimize quality of diagrams** :

- scale (in percent of maximal intensity value: 0.1 up 100%);

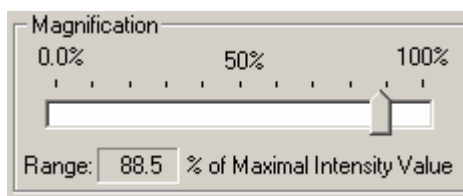

- colors (defined by user);

- types of lines: 14 types with different
  - line style;
  - line width (0 to 10 pixels);

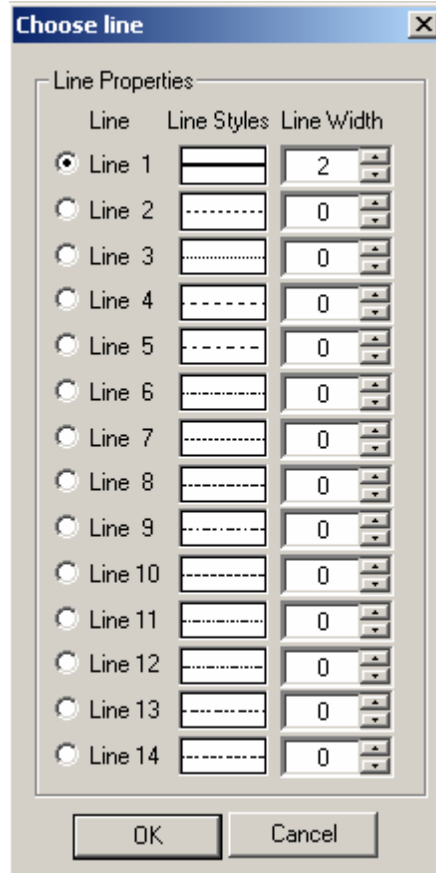

- line options (all solid, all black, black contours);

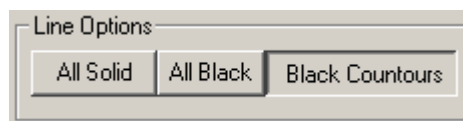

- fill.

In practice, **skeleton lines** are also used for analysis of texture and comparison between different ODFs. Choose radio button with 'Skeleton L.' description to switch for skeleton lines analysis:

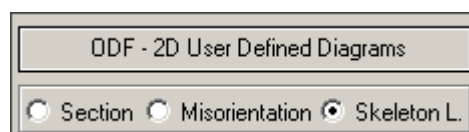

You can choose from two kinds of skeleton lines in section of ‘Skeleton Lines Options’:

- 1) maximum intensity;
- 2) integral (average).

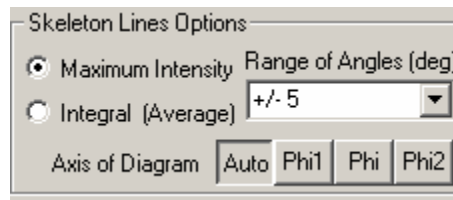

In table below are showed difference between options in dialog “2D User Defined Diagrams (ODF)” :

	<b>Option</b>	X- axis	Y – axis (intensity)
<b>1</b>	<b>Section</b>	Axis defined by ‘Start Point’ and ‘End Point’	Intensity along section
<b>2</b>	<b>Maximum intensity</b> (skeleton lines)	$\phi_1$ or $\Phi$ or $\phi_2$ (defined by user)	Maximal intensity from area close to section line (area defined by user)
<b>3</b>	<b>Integral (Average)</b> (skeleton lines)	$\phi_1$ or $\Phi$ or $\phi_2$ (defined by user)	Integral (Average) intensity from area close to section line (area defined by user)

Examples with construction of  $\beta$ -fibre can help you to find difference between above options. In case of option: ‘Section’ - LaboTex shows intensity strictly along section between **Copper** and **Brass** orientations:

ODF (Cubic C.S., Orthorhombic S.S.)

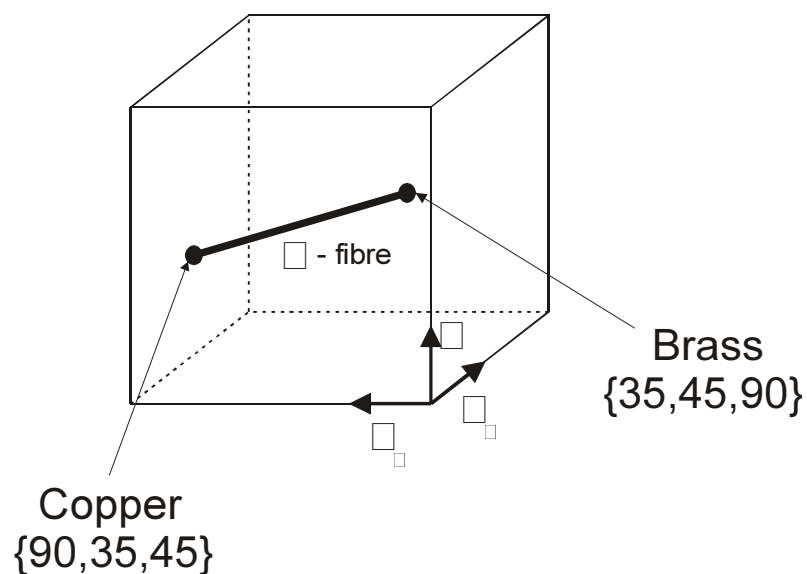

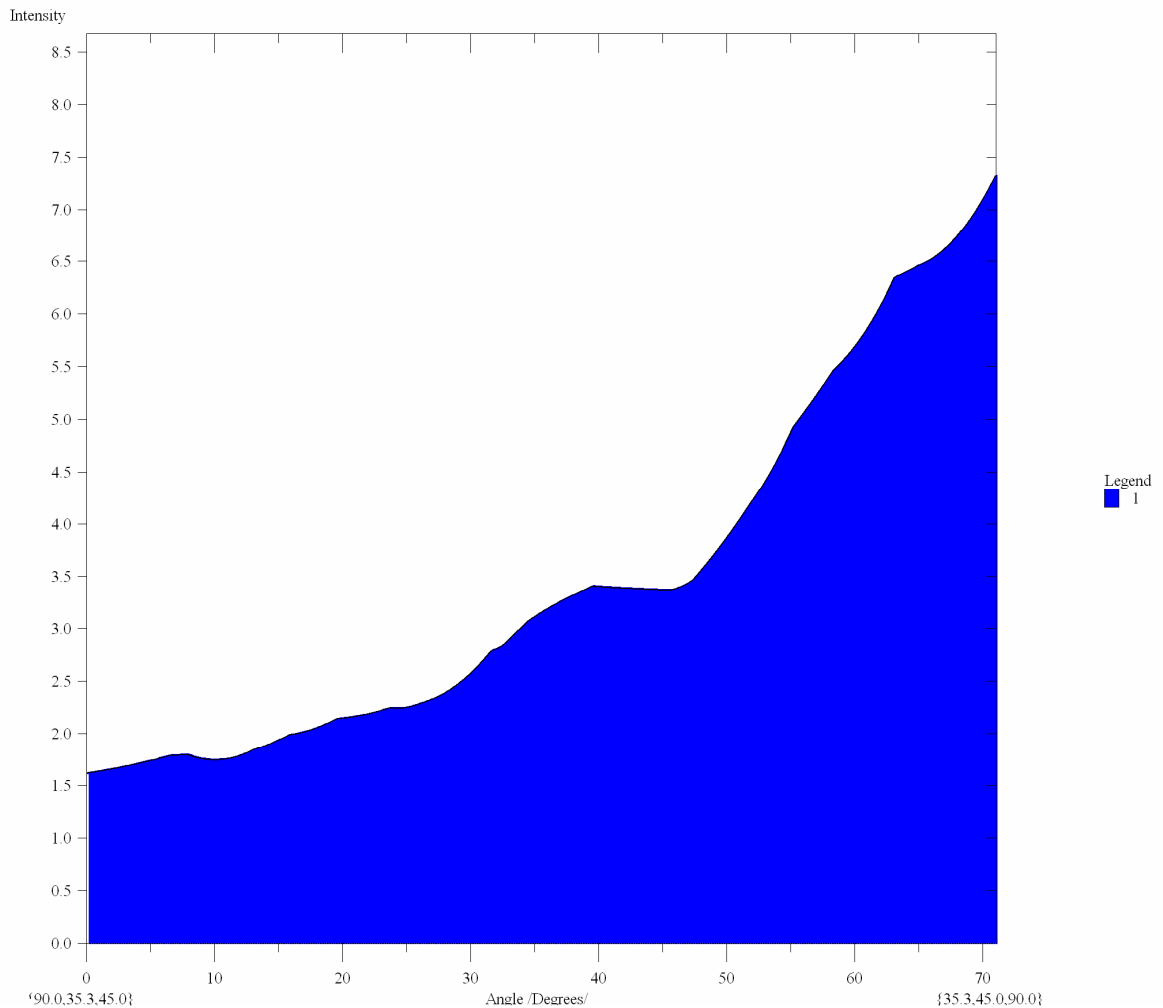

X axis shows distance in degrees between Copper and Brass orientations.

In case of option : **‘Maximum Intensity’** - LaboTex shows line which go over maximums close to axis of diagram. In case of option: **‘Integral’** – LaboTex calculates average intensity from integration of area defined by user. User can change axis of diagram (Phi1, Phi or Phi2) or select **‘Auto’**.

This axis is showed as X axis.

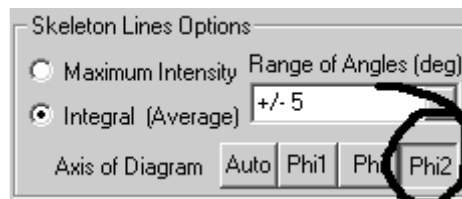

For example: in case of  $\beta$ -fibre LaboTex finds maximums (or average intensity) on each sections along axis of diagram ( $\phi_2$  axis for  $\beta$ -fibre).



# ODF (Cubic C.S., Orthorhombic S.S.)

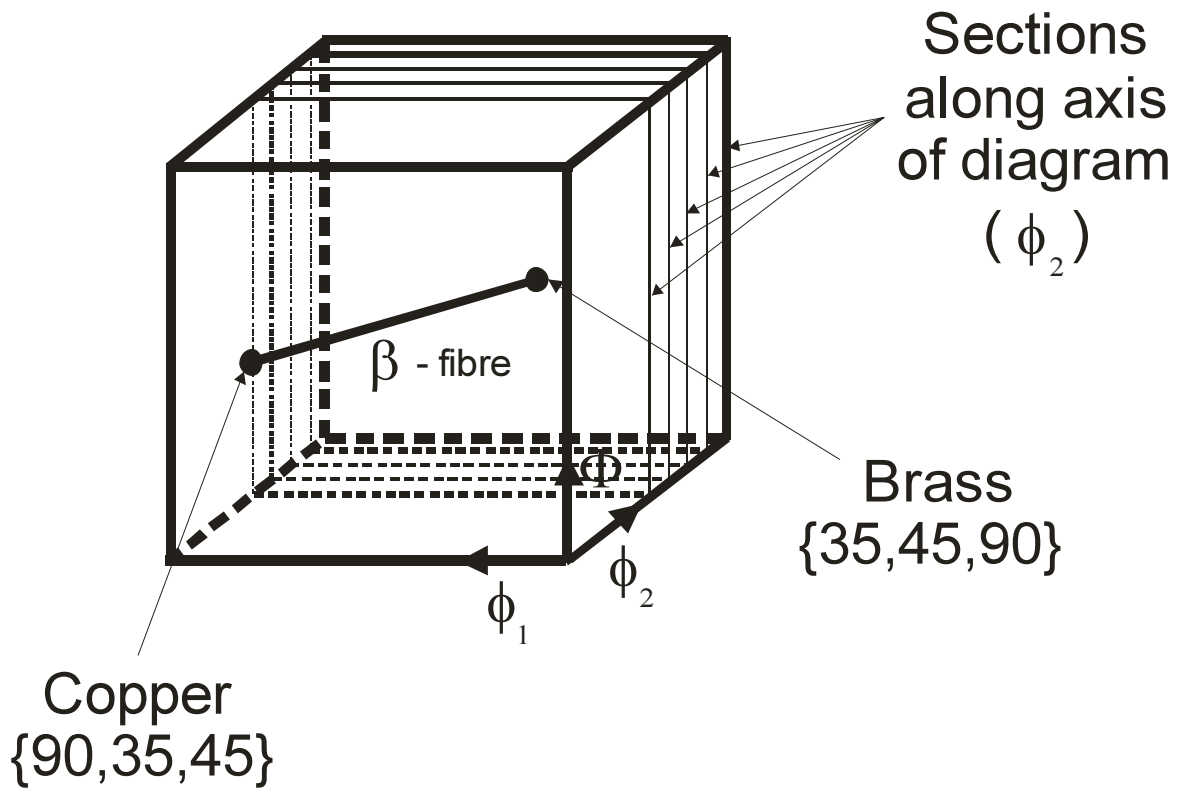

Example of section along axis of diagram

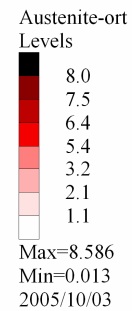
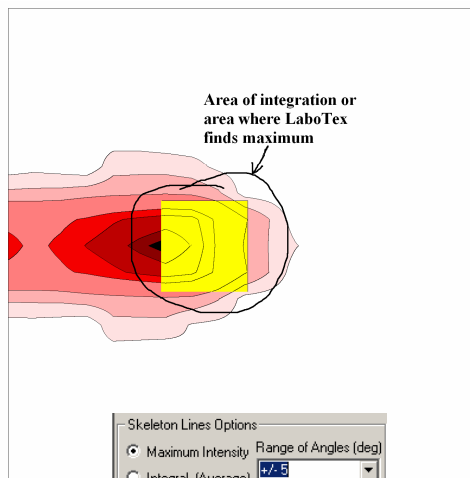

User can also change angles in which finds maximum (from +/-20 degrees).

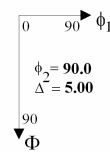
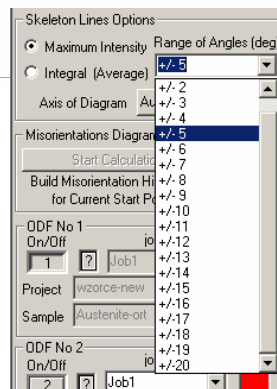

range of LaboTex +/-1 to

# ODF (Cubic C.S., Orthorhombic S.S.)

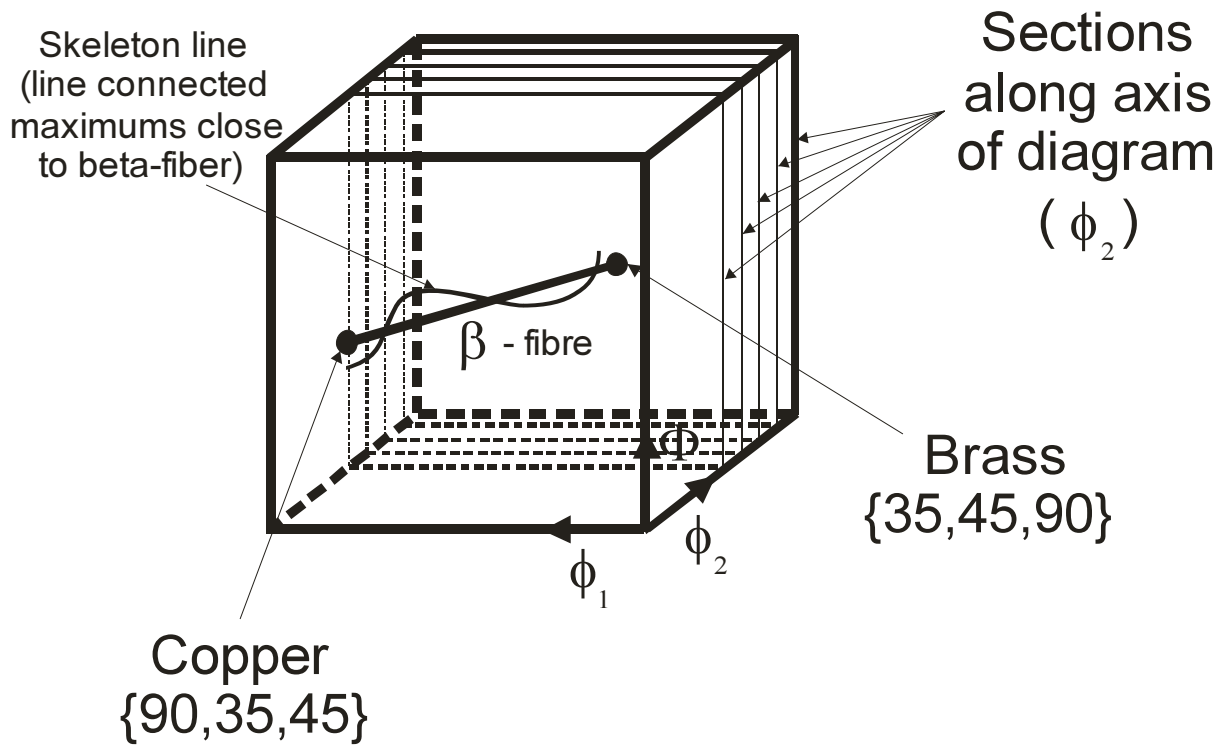

Below you can see skeleton lines diagram for  $\beta$ -fibre with 'Fill' option on:

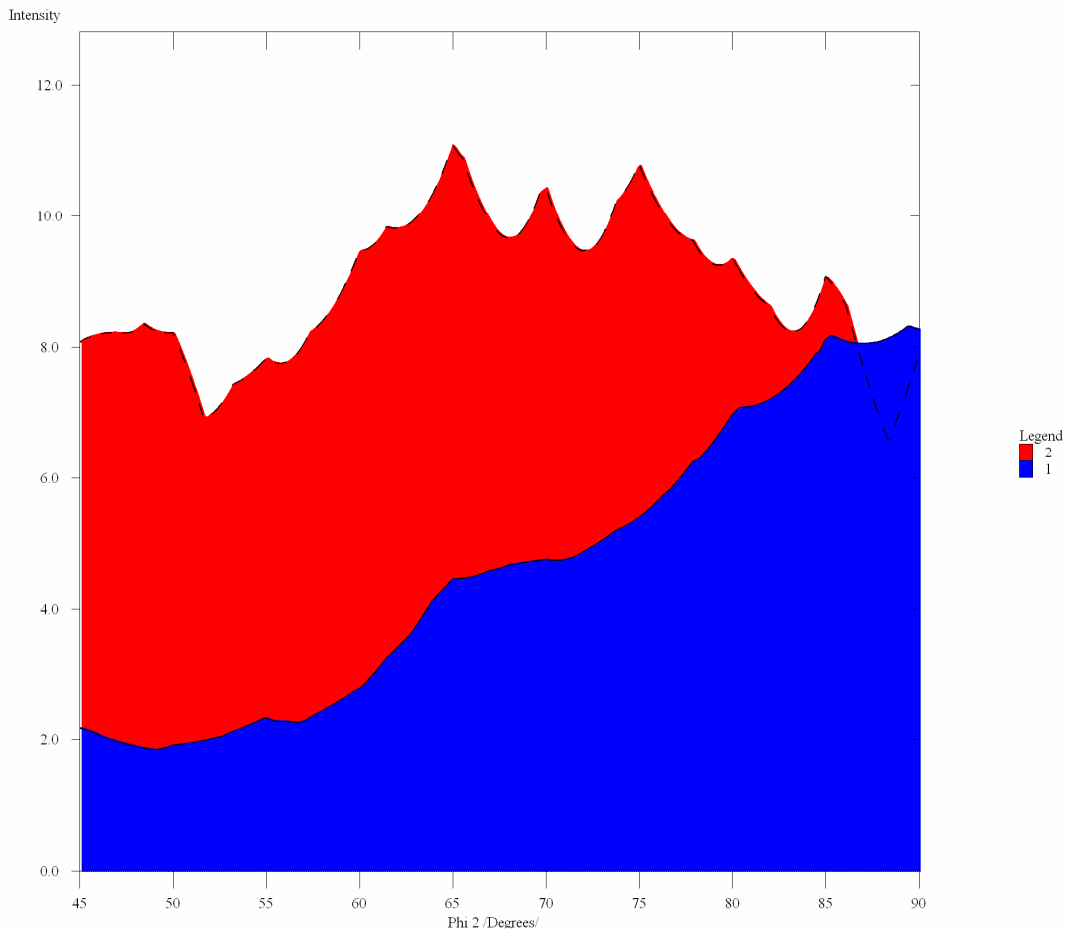

You can save definition of section/fiber (Euler angles) using “**Save Current Parameters/Samples**” button:

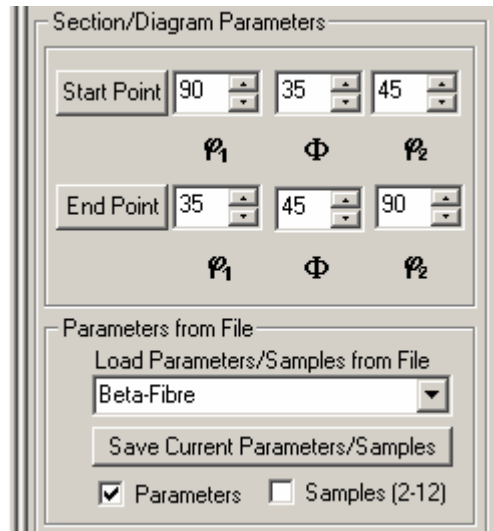

These defined sections/fibers are available from combobox in section: “**Parameters from File**”:

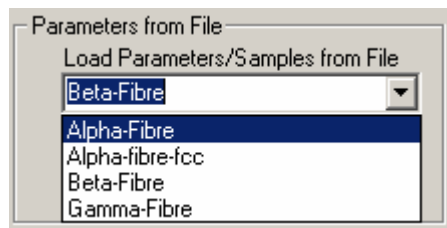

## 2. Misorientation Diagrams

Preparation of misorientation diagrams is very easy in LaboTex. You can start preparation of diagram when you have calculated ODF and this ODF is displayed (button for ODF projection is on). Choose '2D' option (option available from main toolbar). Next you can see from right side of ODF new dialog window : 'ODF- 2D User Defined Diagrams'.

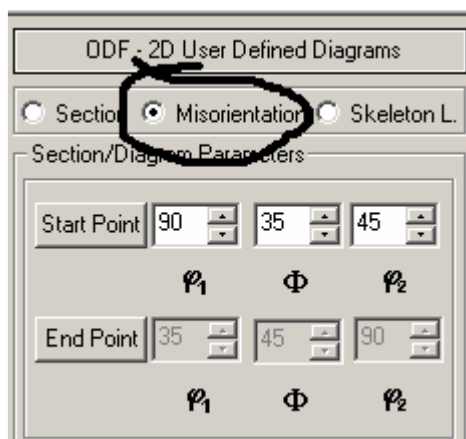

In case of option “**Misorientation Diagrams**” user define only start point in Euler space i.e. point from which LaboTex calculates and shows misorientation diagrams (parameters for ‘End Point’ are grayed). Misorientations diagrams are calculated on the base of ODFs in range 0 to 80 deg from start point (start orientation). User can also choose start point from orientation database. LaboTex shows intensity which is the relative intensity i.e. intensity relate to intensity of random sample ( $I=I(\text{sample})/I(\text{random sample})$ ) for the same range of misorientation angle. User can make comparison up to 12 misorientations histograms. User can also change histogram step in range 1 to 10 degrees:

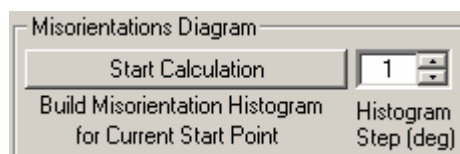

If for given start point LaboTex have not calculated results for misorientation diagram then user should start calculation by pressing ‘**Start Calculation**’ from “Misorientations Diagram” area. LaboTex displays calculation progress:

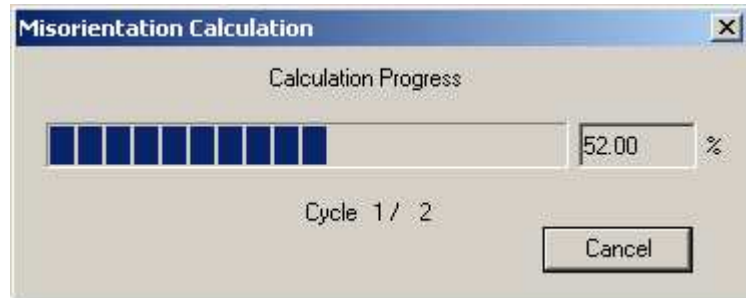

Below you can see example of misorientation diagram:

